

Head Office: Najm Abadi Sq.,
Shams Tabrizi St., Mirdamad
St., Teheran, Iran.

P.O Box: 1549846158

Tel: +98 21 22903200

Fax: +98 21 22279064

Factory: 6th km of Tehran-
arak Road, arak - Iran.

P.O Box: 38135-877

Tel: +98 86 34131220

Fax: +98 86 34131280



CATALOGUE

Sheet Processing Machine

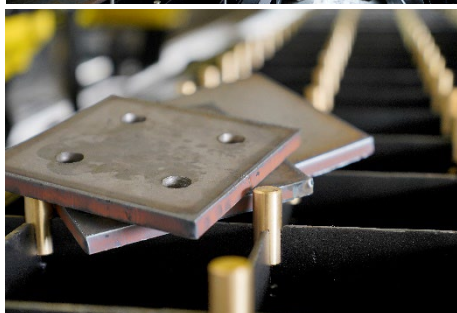
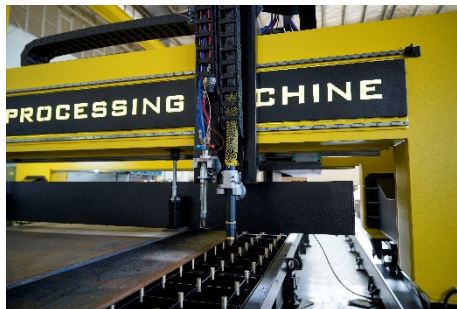



KCCM



KARA SHEET PROCESS Machine

1. Suitable for making exact cuttings in various shapes and sizes using Oxy-Fuel and plasma cutting techniques.
2. Possibility of Oxy-Fuel and plasma torch Installation on the leading head and extra Oxy-Fuel torches attach. (Master - Slave)
3. Having a robust and durable machining structure.
4. Having an accurate and high-speed linear motion using servo motor and precision gearbox with a Very Low Backlash.
5. Equipped with two servo motors and low backlash gearboxes at the two sides of machine for a constant and vibration less motion. (Gantry bridge)
6. possibility of transferring longitudinal motion force of cutting gate using a Planetary for a fast and precise travel speed (Rack Pinion).
7. Possibility of linear movement of cutting torch on the linear guide using a bevel gear for fast and precise movements (Rack pinion and linear guide).
8. Using the TEX Computer torch control system made in Italy with a 2016 performance Version.
9. Equipped with an automatic height control system for torches to prevent crashing of torch and Plate.
10. Equipped with solenoid valves for each torch to avoid oxygen and gas waste, to adjust cutting flame and easy operation.
11. Equipped with flashback arrestor for flame safety.
12. Equipped with robust, integrated and adjustable slide rails for weak inclined workshop bed.
13. Having a set of robust steel and tables and steel band stand which can be replaced easily.
14. Feeding system fitted with ball screw and servo motor controlled by CNC.
15. Cross positioning system with precision gear-reduction, pinion and rack.
16. Auxiliary positioning system for the vertical drilling head with pinion and rack parallel to the main moving axis, suitable to carry out milling operations.
17. Accumulator tank to maintain the proper pressure of the pneumatic clamping jacks
18. pneumatic pilot operated check valve are used to ensure clamp not to fall suddenly in case of not having enough air pressure in compressed air system.





KCCM



Main Technical Specifications (Cutting Part)

1	Sheet Length (mm)	MAX = 6000 x 2500
2	cutting torches	Plasma & Oxy-fuel
3	Plasma cutting's power supply (by default)	Kjellberg PA-S70W
4	Plasma cutting thickness	UP to 70 mm
5	Plasma hole piercing thickness	Air, AR/ ² H ₂ Mixture
6	Oxy-fuel cutting thickness	Single Torch: 5 – 100 mm
7	Maximum jogging speed (mm/min)	6000
8	Machine's control system (optional)	Tex Computer (Italy)
9	Cutting Flame's safety system	Flashback Arrestor
10	Oxy-fuel torch's height adjustment system	Automatic height control (capacitive)
11	Plasma torch adjustment system	Automatic height control (base on arc voltage) Internal for Tex- Computer
12	Protection classification	IP 20
13	Machine's Electric Power Consumption	380V – 50Hz – 3PH – 63A
14	Cable protection and guidance system	Energy chain guide
15	System for turning on oxy-fuel cutting torch	Automatic spark plug transformer
16	Machine's linear movement system	Linear & Cabin- Helical Rack & Pinion
17	Machine's Driving components	Servo motors + planetary gearbox
18	Overall Machine's Dimension (mm) (L, H, W)	10000,5200,3000
19	Overall Machine's Weight (kg)	12000





KCCM



Main Technical Specifications (Drilling Part)

1	Effective workpiece dimensions	Length: 6000 mm, Width: 2500 mm, Thickness: 8 – 70 mm
2	Number of spindles	1 Spindle – BT 40
3	Number of machine axis	3 Axis
4	Specifications and speed range of the spindle	AC Servo Motor: 11 kw Max Spindle Speed: 3000 Rpm
5	Machine's control system	Tex Computer (ITALY)
6	Machine's Control system features	G Code Generation (External Software) – USB
7	Maximum linear velocity of Y axis (Longitudinal movement of the gate)	6000 mm/min
8	Maximum X-axis linear velocity (Transverse spindle motion)	6000 mm/min
9	Maximum Z axis linear velocity (Vertical spindle motion)	5000 mm/min
10	Z-axis motion course (vertical spindle motion)	650 mm
11	Machine's Movement accuracy	± 0.02 mm
12	Machine's Drilling accuracy	Depended to drill life and quality
13	Type of drills	HSS: Min: 6 mm / Max: 35 mm (direct) HSS: Max 40 mm (with leading drill) Drill insert (spade drill) HSS Min: 10 mm / Max: 35 mm Index-able U-Drill: Min 24mm / Max 30 mm
14	Tool change magazine (Optional)	Horizontal Disc Type Magazine / Capacity: 3 Tools Tool Model: BT 40 / Max Tool Length: 320 mm
15	Pneumatic Clamp	4 Jacks
16	Coolant system	Misting Coolant, Internal & External
17	Y-axis motor and gearbox (Longitudinal movement of the gate)	AC Servo Motor: 2x (3Kw – 1000 rpm) Rack & Pinion + Linear Guide
18	X-axis motor and gearbox (Spindle transverse motion)	AC Servo Motor: 1.5 Kw – 1000 rpm Rack & Pinion + Linear Guide
19	Z-axis motor and gearbox	AC Servo Motor: 1.5 Kw – 2000 rpm Electrical Break Pulley and Timing Belt / Ball Screw + Linear Guide
20	Panel's degree of protection	IP 20
21	Machine's Electric Power Consumption (full load)	Nominal Current @ max. load = 380 V – 50 Hz – 3 Ph-35 A
22	Operator's application equipment	Coolant Sprinkler Guns/ compressed air: Blower Guns





Main Technical Specifications (Tables)

1	Effective workpiece dimensions	Length: 6000 mm, Width: 2500 mm, Thickness: 8 – 70 mm
2	Overall table dimensions of each Table	Length:3200 mm, Width :3050 mm, height: 720 mm
3	Proximity sensor of each Table	3 pieces at a distance of 1 meter
4	Pneumatic jack	3 pieces at a distance of 1 meter
5	Exhaust fan	11 Kw, 3000 RPM
6	Brass Spacer	512 pieces
7	Canal	Spiral type

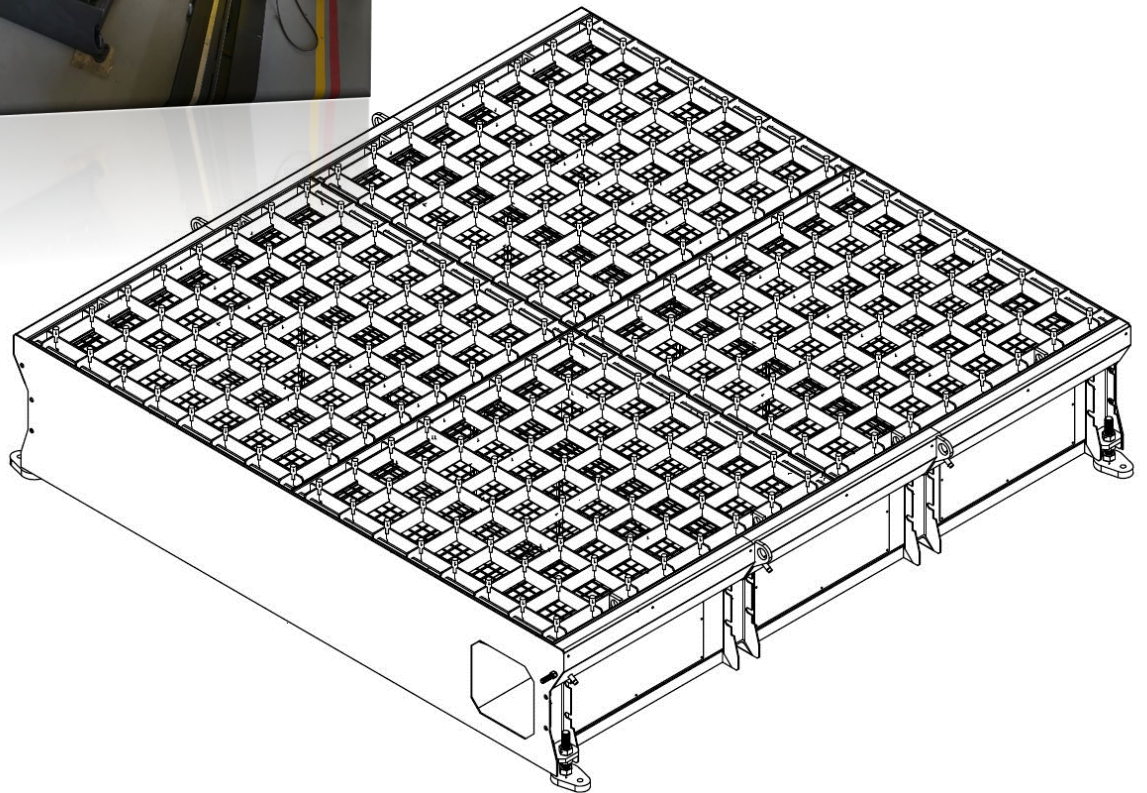
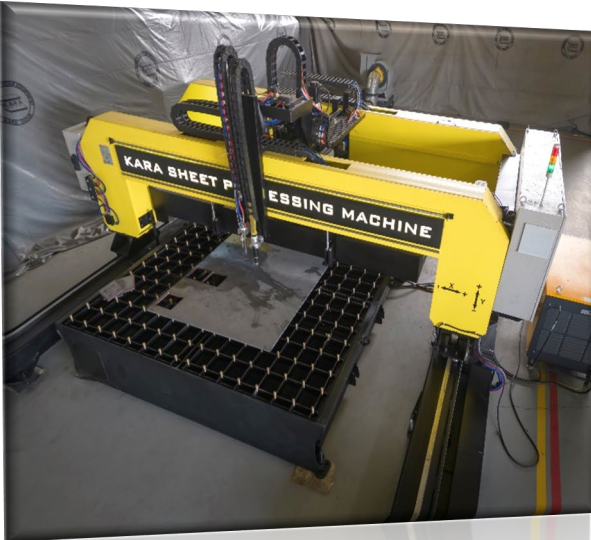

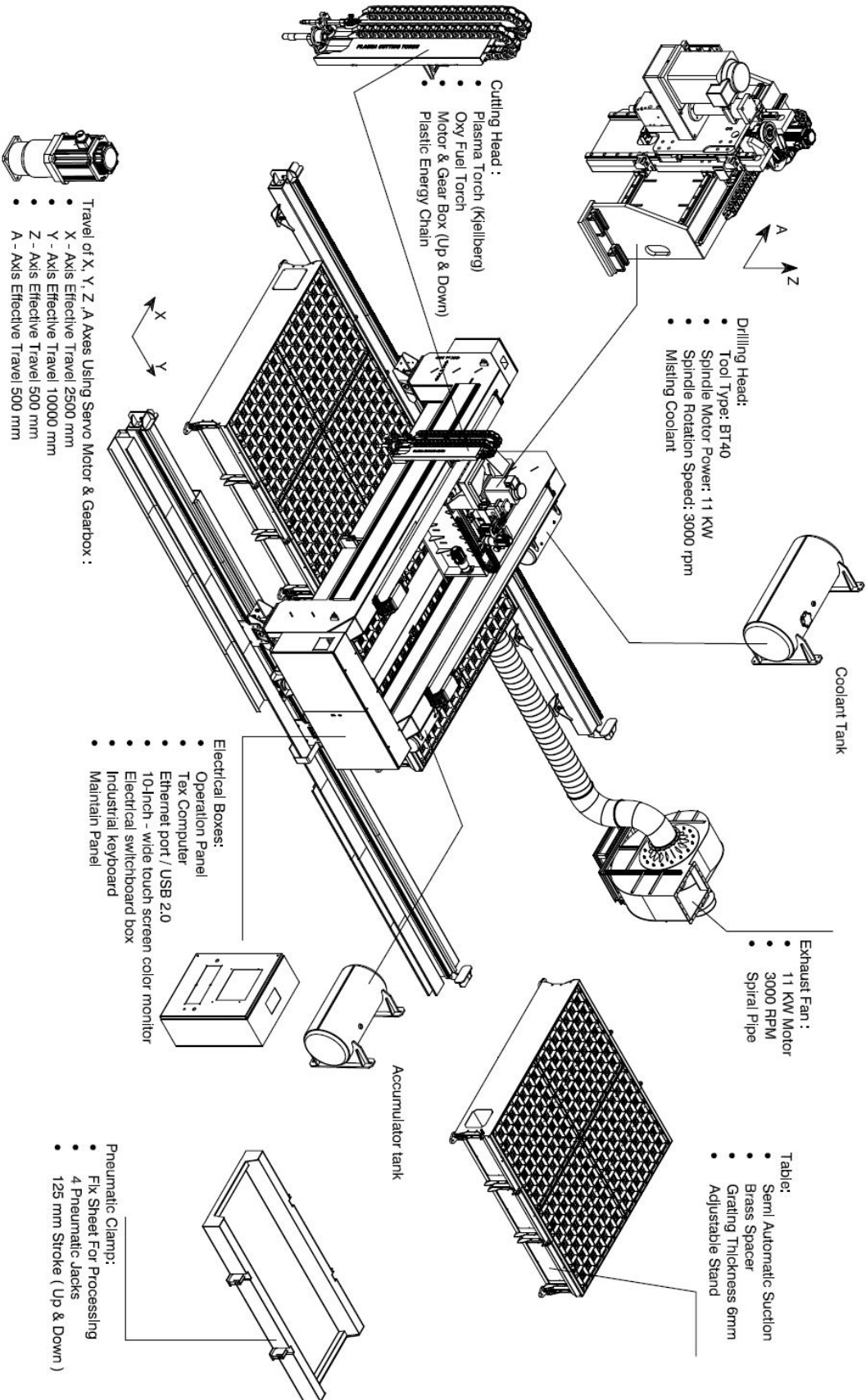



KCCM

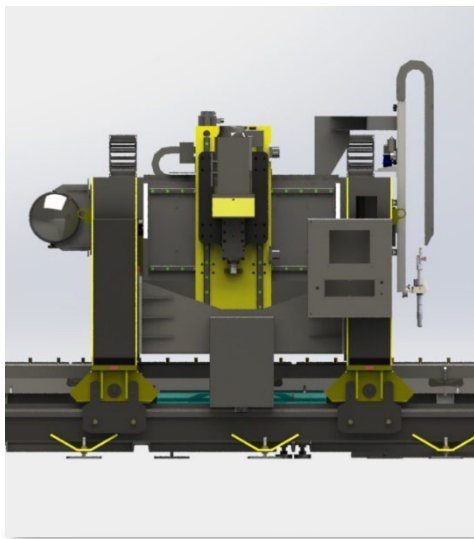
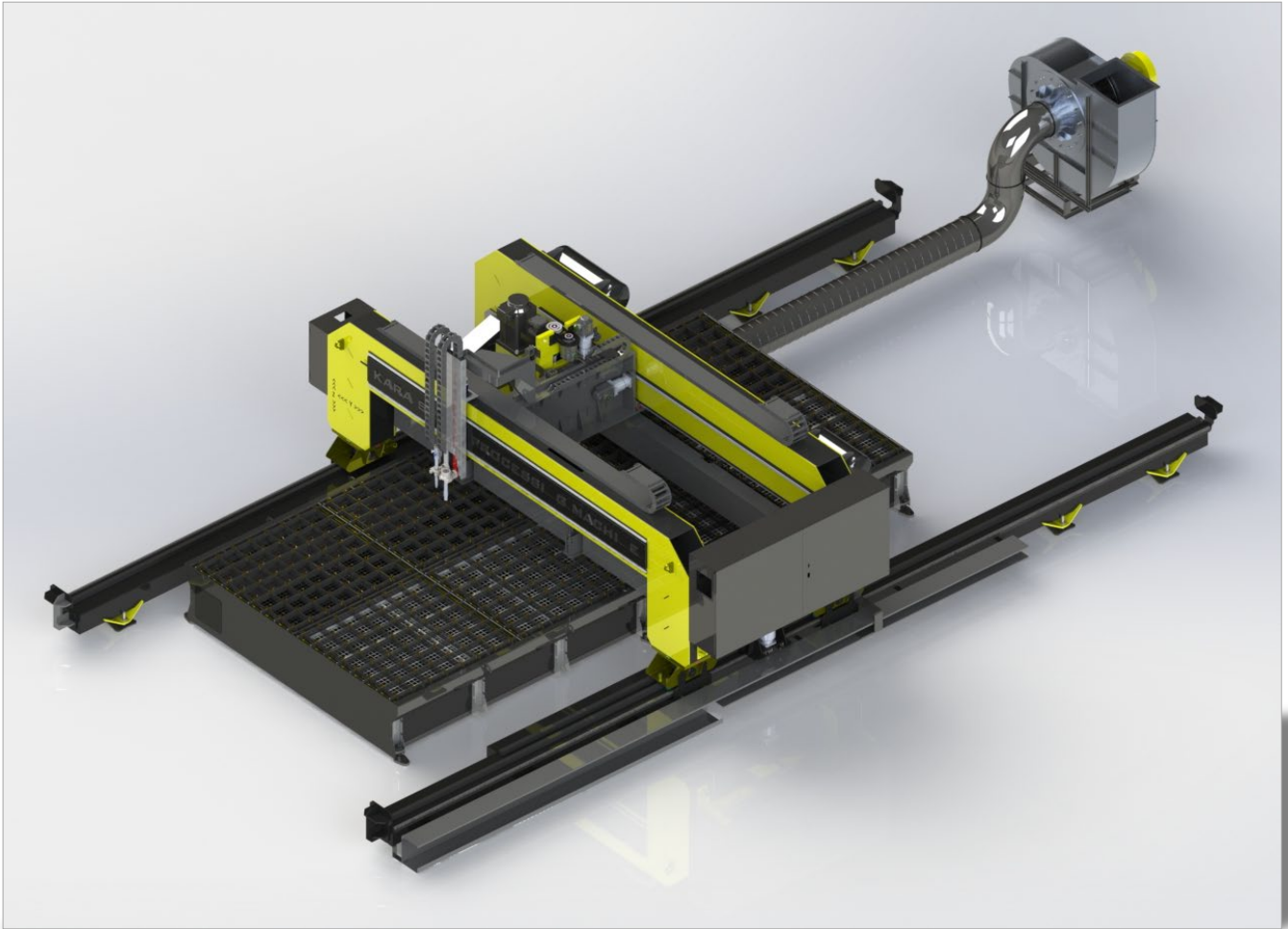

FIGURE NO.1A



FIGURE NO.2B

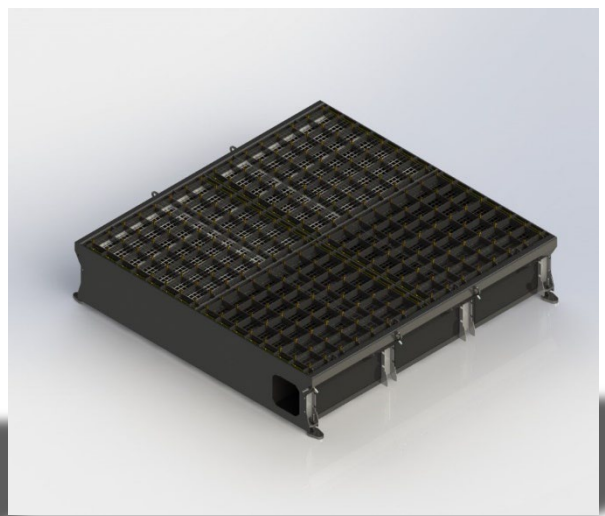

FIGURE NO.3C





KCCM



Machine Control System, Option #1

TexComputer (Italy)

Technical Specifications:

1. Equipped with 6 axillary machine zero points for placing workspace at 6 various locations of machine
2. Transferring Files method: WIFI, Ethernet PORT, USB memory.
3. 10-Inch-wide touch screen color monitor. (65000 colors, 1024x768 pixel)
4. Controlling of Oxy-Fuel or plasma torch at various modes.
5. Adjustable cutting torch Kerf.
6. Predefined figure library.
7. Touch screen and graphic monitor (Persian and English)
8. Backward cutting facility.
9. Connectable mouse and keyboard (for editing codes).
11. A Laser Pointer for Determination of Zero point. (optional)
12. Adjusting plate angle by software.
13. Possibility of Attaching Axis Beveling (optional).
14. G-Code Generator: Pro Nest Software Program (in office).
15. CNC Automatic Torch Height Controller (for plasma torch).
16. Fully-Closed-Loop Servomotor Control System.
17. Cutting Type Software Selection (Oxy-Fuel/Plasma).
18. Controller Technology (ITALY, 2016).





KCGM



Kjellberg[®]
FINSTERWALDE

Welding

Engineering

PLASMA CUTTING & GOUGING

PA-S



Plasmaschneiden & Fugen Plasma Cutting & Gouging

PA-S45 W, PA-S70 W

mit Hand- oder Maschinenbrenner von 3 bis 70 mm
with hand or machine torch from 3 to 70 mm



kjellberg.de





ANLAGEN UNITS

Konturen-, Gerad- & Fasenschnitte bis 60° Contour, Straight & Bevel Cuts up to 60°



Vorteile

- Wahlweiser Einsatz von Hand- oder Maschinenbrenner
- Geeignet für 2D- & 3D-Führungssysteme
- Robuster & einfacher Aufbau
- Fahrbare Anlagen für mobilen Einsatz
- Zuverlässigkeit auch unter schwierigen Produktionsbedingungen
- Schneidstrom in drei Stufen vorwählbar
- Effektive Kühlung des Plasmabrenners & dessen Verschleißteile
- Schnelles Umrüsten von Schneiden auf Plasmafugen & umgekehrt
- Abgewinkelte Brennerköpfe & spezielle Schaftausführungen für optimiertes Schneiden von 3D-Teilen

Advantages

- Optional use of hand or machine torch
- Suitable for 2D & 3D guiding systems
- Robust & simple design
- Portable systems for mobile use
- Reliable even under challenging production conditions
- Cutting current with three settings
- Fluid cooling of plasma torch for long consumable life
- Quick switch from cutting to plasma gouging and vice versa
- Angled torch heads & special shaft designs for optimised cutting of 3D parts

Einfache & preiswerte Technik für jeden Schneidbereich

Die Plasmaschneidanlagen der PA-S-Reihe eignen sich zum manuellen und mechanisierten Schneiden im Materialdickenbereich 3 bis 70 mm. Durch Nutzung unterschiedlicher Plasmagase und Gasgemische können elektrisch leitfähige Materialien sauber geschnitten und gefügt werden. Als fahrbare Anlagen können sie in Werk- und Ausbildungsstätten und auf Baustellen eingesetzt werden.

Simple & inexpensive technology for every cutting range

The plasma cutting systems of the PA-S series are suitable for manual and mechanised cutting of material thicknesses in the range from 3 to 70 mm. The use of a range of different plasma gases and gas mixtures allows the clean cutting and gouging of electrically conductive materials. As portable systems, they can be used in workshops, training centres and on construction sites.

Schneidbereich in mm | Cutting range in mm

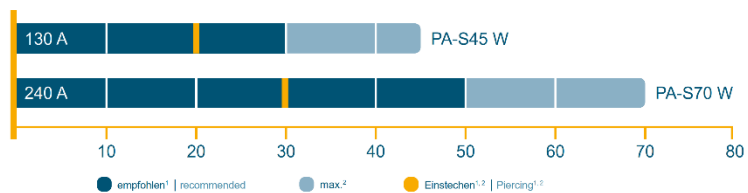

¹ Die Angaben sind abhängig von den zu schneidenden Werkstoffen und deren Zusammensetzung. These data are depending on the materials to be cut and their compositions.

² Einstechregime beachten | Observe piercing capability





Große Einsatzvielfalt durch Zusatzausrüstung Great Versatility with Optional Equipment

Flüssigkeitsgekühlte Plasmabrenner

Voraussetzung für die Qualität der Schnittflächen ist die bewährte Bauform der Brennteile Katode und Düse. Die Flüssigkeitskühlung der Plasma-Feinstrahlbrenner garantiert ihre hohe Lebensdauer. Das Plasmaschneiden mit den Anlagen der PA-S-Reihe ist damit effizient und erhöht die Produktivität des Anwenders. Beim Schneiden von Baustahl mit der PA-S45 W ermöglicht ein Wirbelgasbrenner häufigeres Einstechen.

Liquid-cooled plasma torches

An essential requirement for the quality of cut surfaces is the proven design of the torch's cathode and nozzle. The liquid cooling of the plasma fine-jet torch guarantees longer consumable life. Plasma cutting with the systems in the PA-S series is more efficient by increasing the productivity of the user. For the cutting of mild steel with the PA-S45W, a swirl gas torch allows more frequent piercing.

Plasmafugen

In kurzer Zeit können sowohl Maschinen- als auch Handbrenner zum Plasmafugen umgerüstet werden. Dazu ist ein Wechsel der Düsen und das Aufsetzen der Keramikkappe (gegebenenfalls mit Protektor) erforderlich. Durch den Einsatz unterschiedlicher Plasmagase und Gasgemische lassen sich alle elektrisch leitfähigen Werkstoffe wie Bau- und Edelstahl, Aluminium sowie Messing bearbeiten. Das Plasmafugen eignet sich ausgezeichnet zur Beseitigung von Schweißnahtfehlern, Rissen, Lunkern, Einschlüssen sowie zur Vorbereitung von Gegen-schweißungen.

Plasma gouging

Both the machine and hand torches can be quickly converted for plasma gouging. All you need to do is exchange the nozzles and fit the ceramic cap (with protector where necessary). The use of a range of different plasma gases and gas mixtures allows the machining of all electrically conductive materials, such as mild steel and stainless steel, aluminium and brass. Plasma gouging is ideal for eliminating welding defects, cracks, cavities and inclusions and for preparing for backwelding.



Maschinenbrenner PB-S44 W, PB-S45 W, PB-S70 W
Machine torches PB-S44 W, PB-S45 W, PB-S70 W



Plasmafugen mit dem Handbrenner PB-S45 WH
Plasma gouging with hand torch PB-S45 WH

Vorteile

- Keine Aufkohlung des Materials
- Kein Nachschleifen erforderlich
- Geringer Wärmeeintrag
- Gute Beobachtung der Prozessführung
- Reduzierung von Geräuschpegel & Rauchanfall

Advantages

- No carbonisation of the material
- No finish grinding required
- Low heat input
- Good monitoring of process management
- Reduction of noise & smoke levels



Räderwagen | Wheel guide



Kreisschneideinrichtungen
Circle cutting attachment



Fasenkronen | Bevel cap



Fasenschneideinrichtung
Bevel cutting attachment



Protektor für Plasmafugen
Protector for plasma gouging



Schablonenschnitte
Template cutting

Für manuelle Schneidaufgaben steht je Brennertyp eine Vielzahl an Zubehör zur Verfügung.

For manual cutting tasks, a wide range of accessories is available for each type of torch.



KCGM



Kjellberg®
FINSTERWALDE

Schweißen

Maschinenbau

PLASMASCHNEIDEN & -FUGEN

PA-S

Technische Daten Technical data	PA-S45 W	PA-S70 W
Netzspannung¹ Mains voltage¹	3 x 400 V, 50 Hz	3 x 400 V, 50 Hz
Sicherung, träge Fuse, slow	63 A	125 A
Anschlussleistung Connected load	38 kVA	76 kVA
Schneidstrom Cutting current	45 A bei 100 % ED 45 A at 100 % d.c. 85 A bei 100 % ED 85 A at 100 % d.c. 130 A bei 60 % ED 130 A at 60 % d.c.	80 A bei 100 % ED 80 A at 100 % d.c. 160 A bei 100 % ED 160 A at 100 % d.c. 240 A bei 80 % ED 240 A at 80 % d.c.
Abmessung (L x B x H) Dimensions (L x W x H)	1025 x 711 x 970 mm	1380 x 870 x 1080 mm
Masse Mass	240 kg	460 kg

Maschinenbrenner Plasma torch	PB-S44 W	PB-S45 W	PB-S70 W
Max. Schneidstrom bei 100% ED Cutting current 100 % d.c.	130 A	130 A	240 A
Schneidbereich Cutting range	bis 40 mm up to 40 mm	bis 45 mm up to 45 mm	bis 70 mm up to 70 mm
Plasmagase Plasma gas	Luft, Ar/H ₂ -Gemisch Air, Ar/H ₂ mixture	Luft, Ar, H ₂ Air, Ar, H ₂	Luft, Ar/H ₂ -Gemisch Air, Ar/H ₂ mixture
Wirbelgase Swirl gas	Luft, N ₂ Air, N ₂	-	-
Brennerkühlung Torch cooling	„Kjellfrost“		

¹ andere Spannungen und Frequenzen auf Anfrage | other voltages and frequencies on request

03|01|21

Auszug Schneiddaten | Extract operating data

PA-S45 W

Dicke Thickness mm	Baustahl Mild steel		Edelstahl Stainless steel		Aluminium	
	A	mm/min	A	mm/min	A	mm/min
3	45	2000	-	-	-	-
5	85	2500	85	2500	85	3400
10	130	2000	130	2150	130	3000
15	130	1300	130	1700	130	2100
20	130	800	130	1000	130	1300
25	130	500	130	700	130	900
40	130	200	130	200	130	300
45	130	200	130	200	130	150

PA-S70 W

Dicke Thickness mm	Baustahl Mild steel		Edelstahl Stainless steel		Aluminium	
	A	mm/min	A	mm/min	A	mm/min
4	160	3000	160	2630	-	-
6	160	3150	160	2200	160	3500
8	160	2500	160	1750	160	3000
10	240	2600	160	1500	160	2000
15	240	1300	160	1000	160	1700
20	240	1100	240	1050	240	1750
30	240	800	240	530	240	1250
40	240	500	240	500	240	1000
50	240	230	240	350	240	600
60	240	200	240	200	240	350
70	240	125	-	-	240	250



Kontakt | Contact

Kjellberg Finsterwalde Plasma und Maschinen GmbH

Oscar-Kjellberg-Str. 20 | 03238 Finsterwalde | Germany | 📞: +49 3531 500-0 | 📠: +49 3531 500-299

sales@kjellberg.de | Copyright © 2021 Kjellberg Finsterwalde

Connect with Kjellberg – Always on!

kjellberg.de

Änderungen vorbehalten | Subject to change without prior notice





KCGM



KARA Quality Certificates



Contact US



www.karasazeh.com



araksales@karasazeh.com



[kara_groups](https://www.instagram.com/kara_groups)



[karasazehgroup](https://www.youtube.com/karasazehgroup)

