

Head Office: Najm Abadi Sq.,
Shams Tabrizi St., Mirdamad
St., Teheran, Iran.
P.O Box: 1549846158
Tel: +98 21 22903200
Fax: +98 21 22279064

Factory: 6th km of Tehran-
arak Road, arak - Iran.
P.O Box: 38135-877
Tel: +98 86 34131220
Fax: +98 86 34131280



CATALOGUE

Elbow Welding Machine





KARA Elbow Machine

Welding Line Applicable: Various butt-welding lines of spool pieces such as pipe-pipe, pipe-elbow, pipe-flange, flange-flange and flange-elbow, etc.

Applicable Materials: Carbon steel, alloy steel, stainless steel

Clamping System to holding workpieces

Machine movement: column moving by hydraulic jack & beam moving by motor & Gear Box

Conveyor movement: Precise rotary motion with controllable speed

Main Technical Specifications		
1	Machine Dimensions (mm)	3600 x 2400 x 2750
2	Max Pipe Diameter	760 mm ~ 30 "
3	Clamp actuator	Hydraulic Jack \varnothing 80
4	Left & Right actuator	DC Motor & Worm Gearbox
5	Up & Down actuator	Hydraulic Jack \varnothing 80
6	Machine's Electric Power Consumption	380V - 16A
7	Protection classification	IP 20
8	Machine Weight	4500 Kg
9	Saddle	Roller Bed (4 x \varnothing 320)
10	Power Source	TIG-Kara KTW 400
11	Torch actuator	Slider With waving torch
12	Rotator Gearbox	Planetary Halo shaft
13	Rotator Servo	Delta / Estun 1KW -1000RPM
14	Guide way	Linear & Cabin 45



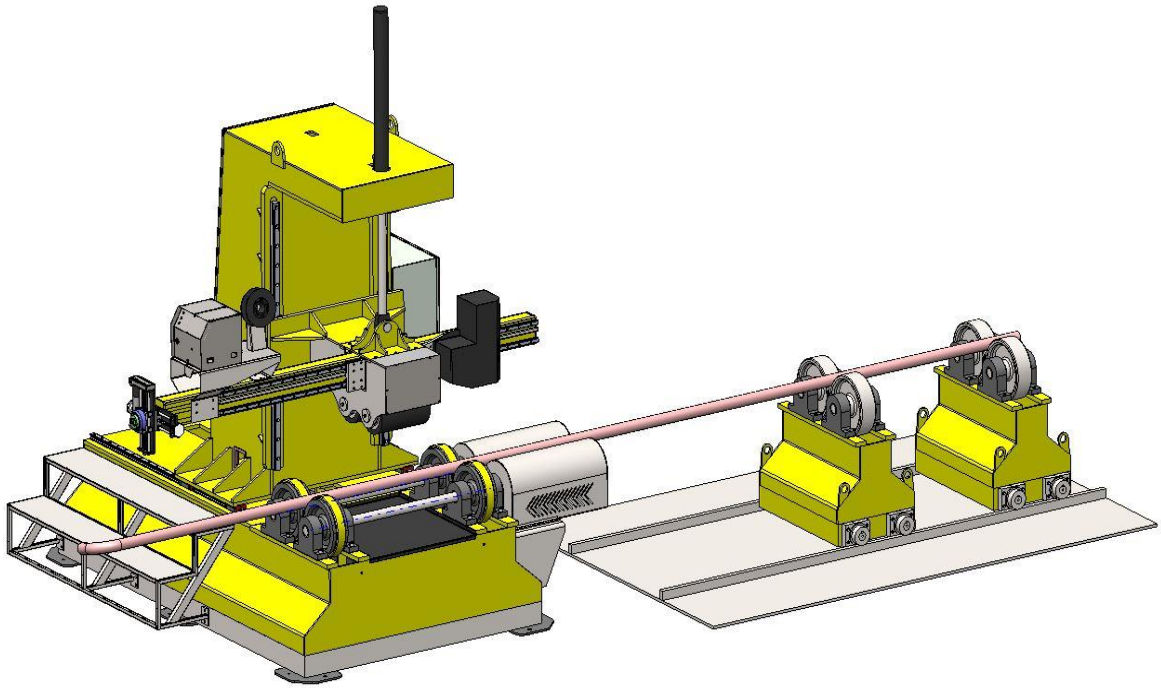



TCK 600H/600S/400



کاربرد:

- جوش با گاز محافظ
- جوش به روش سیم توپودری

ویژگی‌ها:

- برق ورودی سه فاز
- کنترل ولتاژ خروجی سلکتوری ۲۴/۳۲ حالت، جهت دستگاه ۴۰۰/۶۰۰
- تایمر تنظیم زمان جوشکاری
- سیستم هوا خنک / آب خنک
- جوشکاری تا سقف ۶۰۰ آمپر / ۴۰۰ آمپر
- مناسب برای جوشکاری ورق‌های فولاد معمولی، آلومینیوم، استنلس استیل
- قابلیت جداسازی قسمت هدایت سیم از منبع تغذیه جهت استفاده در ارتفاع یا محلهایی که امکان حمل منبع تغذیه وجود ندارد.
- تنظیم دقیق سرعت سیم، آمپر و ولتاژ
- آمپر متر و ولت‌متر دیجیتال (عقره‌ای)
- حمل آسان
- استفاده از قسمت هدایت سیم چهار غلتکه
- قابلیت استفاده از تورچ هوا خنک / آب خنک
- سوکت خروجی ۲۲۰ ولت جهت هیتر گاز

Usage:

- Gas metal - Arc welding (MIG/MAG)
- Flux cored Arc welding (FCAW)

Features:

- 3 phase power
- 32/24 position voltage adjustment (Selector)
- Welding time controller
- Air cool / Water cool
- Perfect & even welding of steel, stainless steel, aluminum, copper
- Common welding: GMAW - FCAW
- Percise adjustment of wire speed, voltage & current controller
- 4 wheels drive with smooth wire feed, no deformation of soft wires
- Digital voltmeter & ampmeter
- Air cool / Water cool torch
- 220 V socket for gas heater plugging

Technical Data:

Models	TCK 250	TCK 400	TCK 500	TCK 600S	TCK 600H
Type of voltage control	Selector switch	Selector switch	Selector switch	Selector switch	Selector switch
Voltage step	4*4	4*6	2*4*4	2*4*4	2*4*4
Setting range	50A/14V-250A/28V	50A/14.5V-350A/32V	50A/15V-600A/44V	50A/16V-500A/39V	50A/16V-600A/44V
Max. load at 60% duty cycle	250A	350A	600A	500A	600A
Max. load at 80% duty cycle	210A	300A	500A	430A	500A
Max. load at 100% duty cycle	190A	270A	430A	280A	430A
Open circuit voltage	18~45 V DC	18~50 V DC	19~55 V DC	19~55 V DC	19~55 V DC
Fuse time lag	20 A	32 A	40 A	40 A	40 A
No load power	200 W	200 W	200 W	200 W	200 W
Input power	3 PH 380 V 50 Hz	3 PH 380 V 50 Hz	3 PH 380 V 50 Hz	3 PH 380 V 50 Hz	3 PH 380 V 50 Hz
Full load Cosφ	0.82	0.82	0.82	0.82	0.82
Full load efficiency	0.79	0.79	0.79	0.79	0.79
Cooling type	Air circulate with fan	Air circulate with fan	Air circulate with fan	Air circulate with fan	Air circulate with fan
Protection class	IP 22	IP 22	IP 22	IP 22	IP 22
Insulation class	H	H	H	H	H
Dimension L*W*H	770/510/750 mm	620/510/920 mm	670/510/920 mm	670/510/920 mm	670/510/920 mm
Weight	135 kg	195 kg	270 kg	225kg	270kg
Wire feeder type	Internal	KWF 22	KWF 22	KWF 22	KWF 22
Wire feeder voltage	42 V AC	42 V AC	42 V AC	42 V AC	42 V AC
Wire diameter	0.8 , 1.0	0.8 , 1.0 , 1.2	0.8 , 1.0 , 1.2 , 1.6	0.8 , 1.0 , 1.2 , 1.6	0.8 , 1.0 , 1.2 , 1.6
Number off roll	4	4	4	4	4
Wire feeder protection class	IP 20	IP 20	IP 20	IP 20	IP 20
Max. wire speed	16m/min	18m/min	18m/min	18m/min	18m/min
Wire feeder dimension	---	200/600/250 mm	200/600/280 mm	200/600/280 mm	200/600/280 mm
Wire feeder weight	---	18.2 kg	18.2 kg	18.2 kg	18.2 kg
Torch socket	Euro connection	Euro connection	Euro connection	Euro connection	Euro connection



KARA Quality Certificates



Contact US



www.karasazeh.com



araksales@karasazeh.com
sales@karasazeh.com



[karagroup.official](https://www.instagram.com/karagroup.official)



[kara-sazeh-official](https://www.youtube.com/kara-sazeh-official)



[kara-sazeh-official](https://www.youtube.com/kara-sazeh-official)

