



# CATALOGU

## Pipe Flange Welding Machine





# KRWCM



## Main Technical Specification Flange Welding

1	Welding Type	Mig/Mag
2	Welding Device	TCK 514
3	Number Of Welding Head	2
4	Workpiece	Cap : 6-16 Inch Without Fixture Tube : 6-24 Inch
5	Boom Vertical Stroke	1350 mm
6	Boom Horizontal Stroke	3000 mm
7	Boom Vertical Speed	800 mm/min
8	Boom Horizontal Speed	800 mm/min
9	Boom Vertical Mechanism	Linear guideway - Rack & Pinion - Electromotor & Worm Gear Gearbox
10	Boom Horizontal Mechanism	Linear guideway - Rack & Pinion - Electromotor & Worm Gear Gearbox
11	Positioner Turning Mechanism	Gear & Pinion - Electromotor & Worm Gear Gearbox
12	Positioner Turning Speed	To 1 RPM
13	Roller Bed Turing Mechanism	Gear & Pinion - Electromotor & Worm Gear Gearbox
14	Roller Bed Turing Speed	To 20 RPM
15	Roller Bed Wheel	Iron with PU
16	Control System	PLC
17	IP Classification	IP22
18	Power Supply	380V-50Hz 3PH - 16 A
19	Chassis Overall Dimensions	x 1500 mm x 1140 mm mm2500





# KRWCM

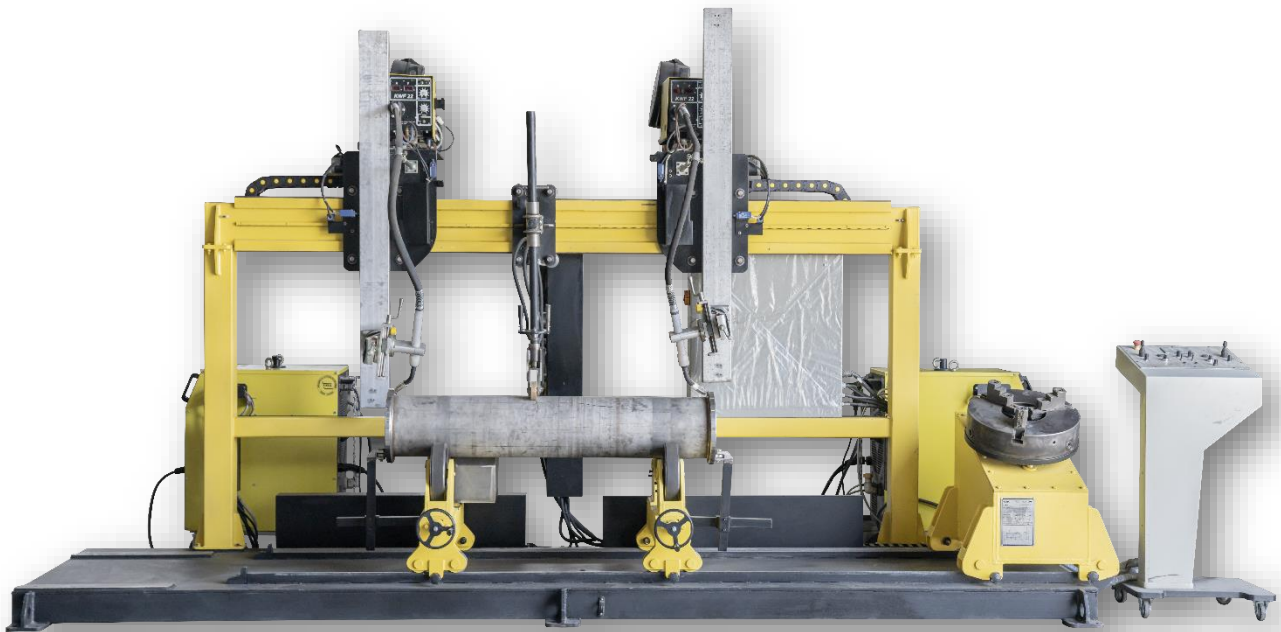
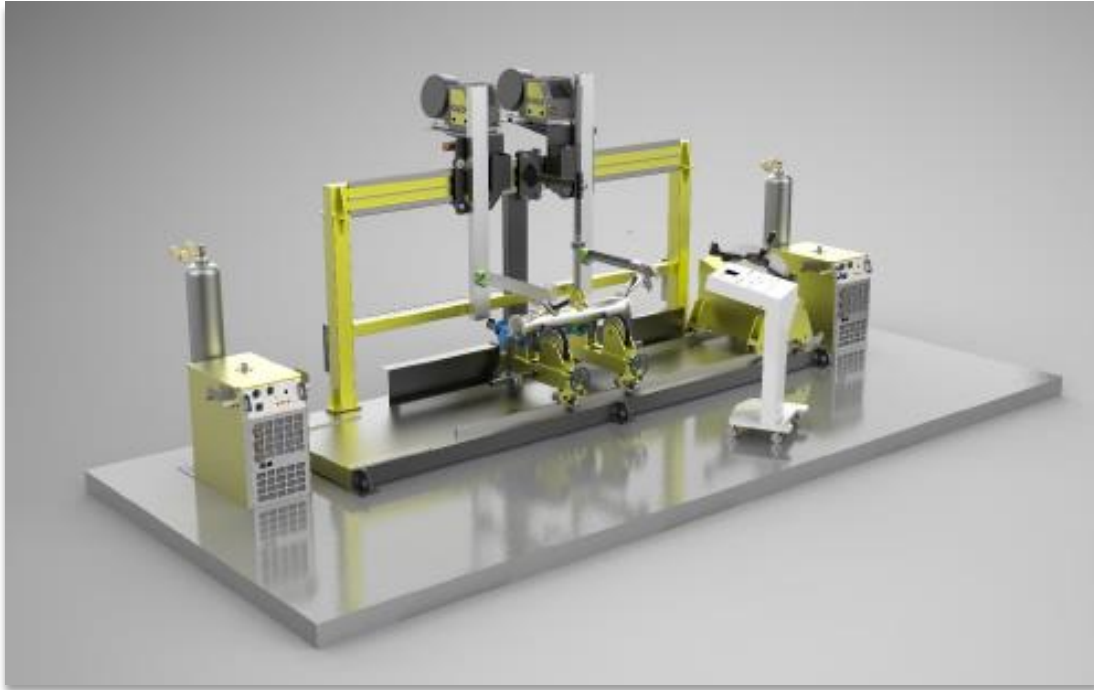



## KARA Pipe Flange Welding Machines

Flange Welding machine have the following features :

1. It has a Mig/Mag welding system with accurate ampere and voltage control during welding according to the required standard .
2. It has a Shell rotation speed control system by Servo Motor .
3. It has a Cap rotation speed control system by Stepper Motor .
4. Has a fixture to hold the Shell on both sides of the Flanges .
5. Ability to weld parts in addition to Shell- types of rollers .
6. It has 2 sets of Roller Bed that one of the are motorize .
7. Ability to load up to 3 tons on the machine's turntable .
8. Work and easy operation .
9. Speed and quality in Shell And Tube Sheet welding operations . The ability to adjust the height in three X.Y.Z axes to a course of 100 mm .
10. Ability to weld all kinds of Shell and Tube Sheet used in industries with different sizes .
11. It has a welding connection system without contact and damage to the shaft and the surfaces under the bearing .



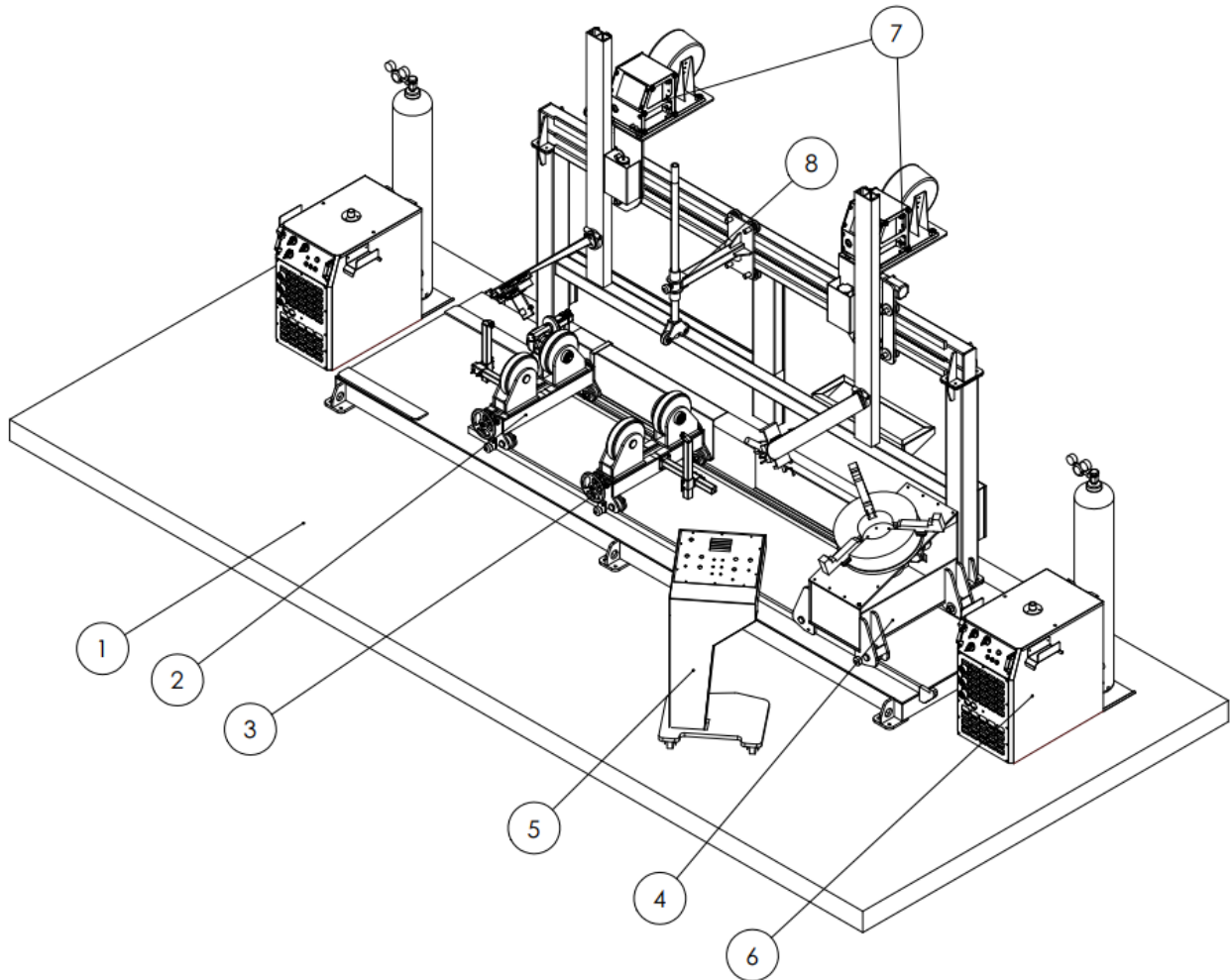

Flange Welding Machine	
1	Base
2	Motorize Roller Bed
3	Idler RollerBed
4	Horizontal Positioner
5	Remote Control
6	TCK 514 Welding power Source
7	Wire Feeder
8	Shell Clamp



# KRWCM



## Contact US

Head Office: Najm Abadi Sq., Shams Tabrizi St., Mirdamad St., Tehran, Iran.



Tel: (+9821)22903200 (12 lines)

Fax: (+9821)22279064

Factory: 6<sup>th</sup> Km of Tehran - Arak road, Arak - Iran. P.O Box: 38135-877

Tel: (+9886)34131220 (10 lines)

Fax: (+9886)34131280



[www.karasazeh.com](http://www.karasazeh.com)



[sales@karasazaeh.com](mailto:sales@karasazaeh.com)



[karagroup.official](https://www.instagram.com/karagroup.official)

[araksales@karasazeh.com](mailto:araksales@karasazeh.com)



[Kara-sazeh-official](https://www.youtube.com/Kara-sazeh-official)



[kara-sazeh-official](https://www.youtube.com/kara-sazeh-official)

